

OUTDOOR WORKOUT EQUIPMENT

Outdoor

INSTRUCTION
MANUAL FOR
ASSEMBLY OF
ELEMENTS OF
SPORTS COMPLEXES

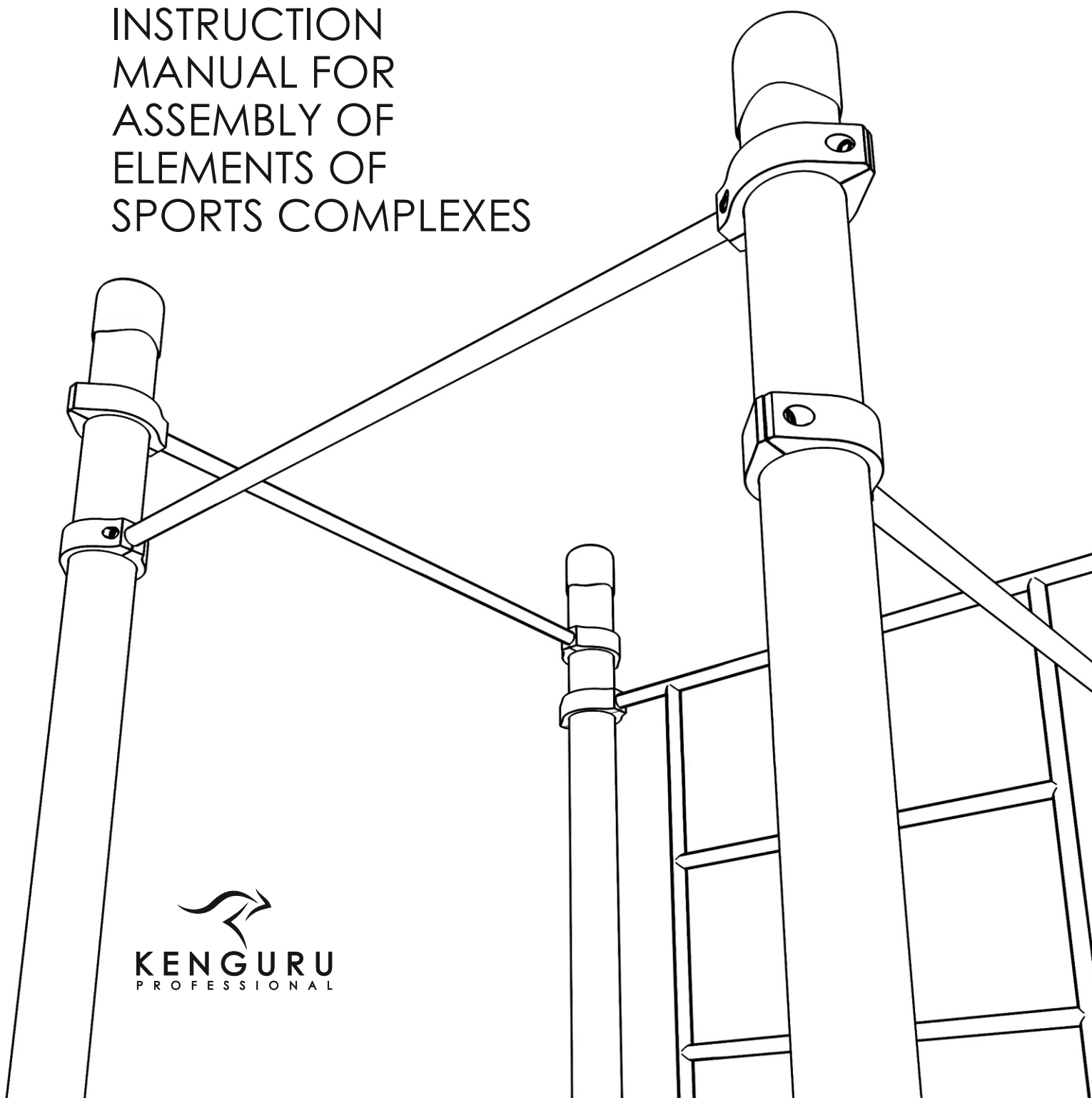

A

ELEMENTS and FASTENERS

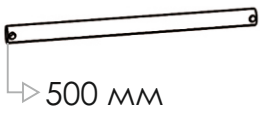

E-001

Horizontal bar



E-002

Horizontal bar

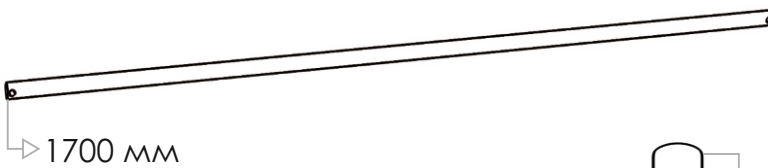

E-003

Horizontal bar

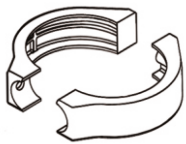

E-000

Clamp

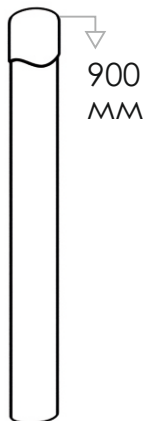

E-005



E-006

Vertical column



E-007

Vertical column

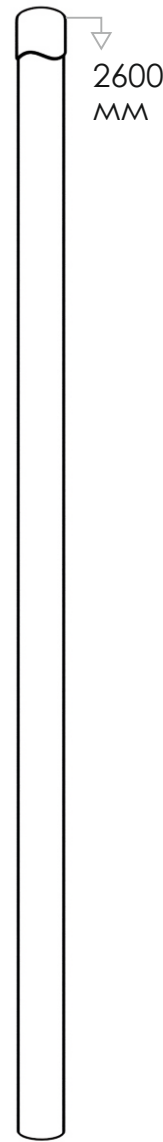

E-008

Vertical column

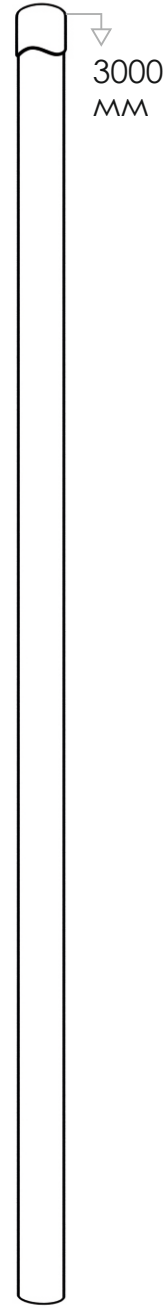

E-009

Vertical column



E-010

Vertical column

E-011
Workout desk

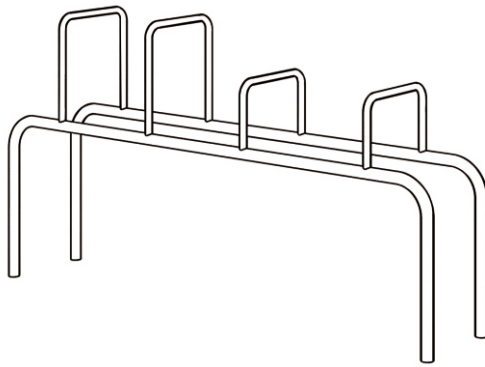

E-012
Swedish wall

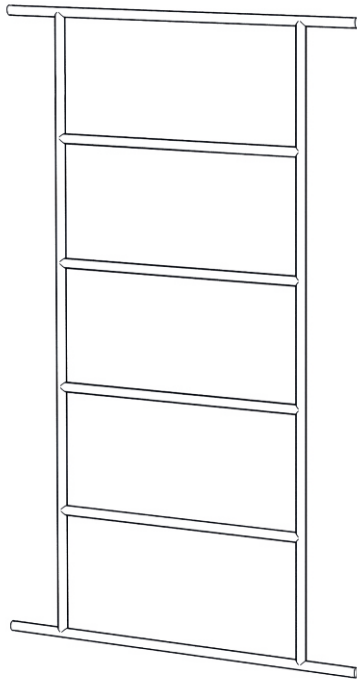

E-013
Monkey bar

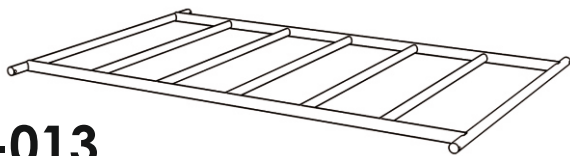

F-007
Elevated
Monkey bar

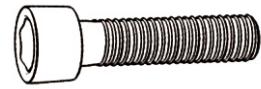
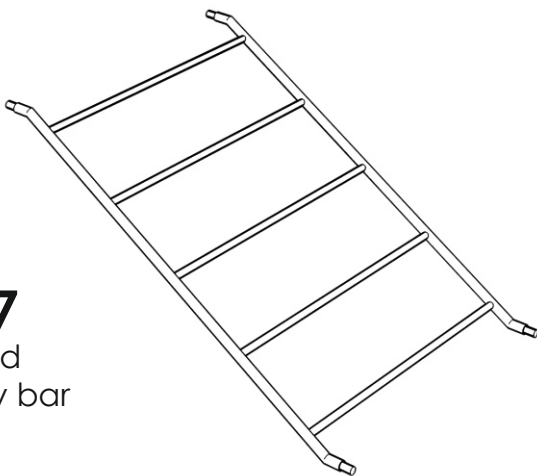

DIN 60

Grade 8.8
Allen-head screw;
M10*60

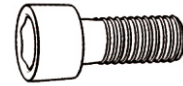

DIN 35

Grade 8.8
Allen-head screw;
M10*35

**MAXIMUM TORQUE OF THREADED
CLAMP FASTENER DURING
INSTALLING = 50-55 Nm**

E-014

Parallel bar

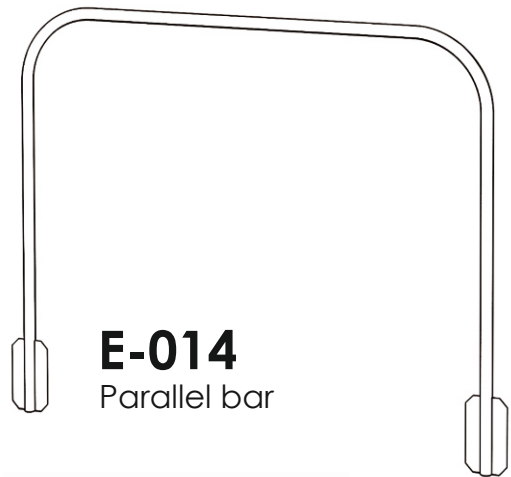

E-016

Snake bar

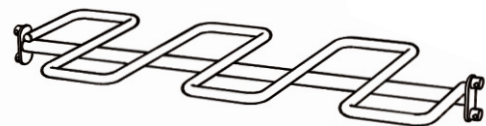

E-017

Wooden
beam

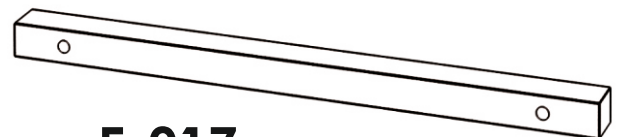

B

ASSEMBLY

The assembly of the elements on the grounds is carried out in the following sequence:

1. POSITIONING OF THE GROUNDS

The grounds are marked along the centers of the vertical columns in accordance with the scheme of the complex

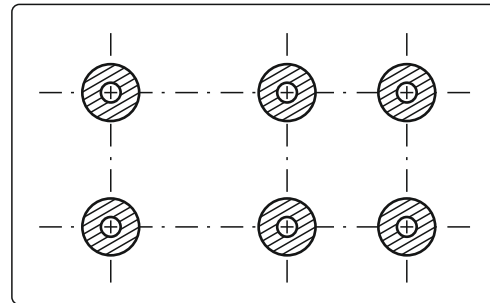

2. PREPARATION OF HOLES FOR COLUMNS

E-005, E-006

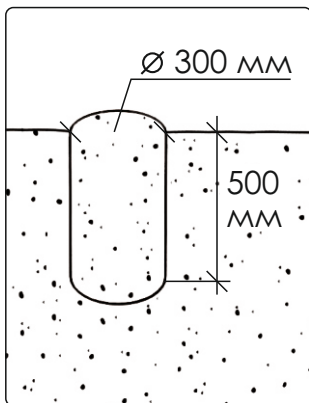

E-007, E-008

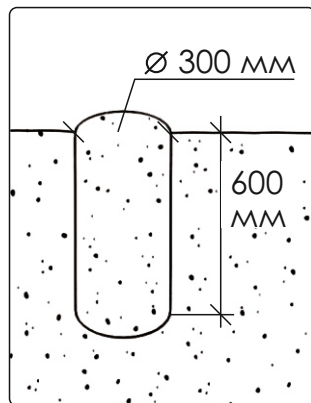

E-009, E-010

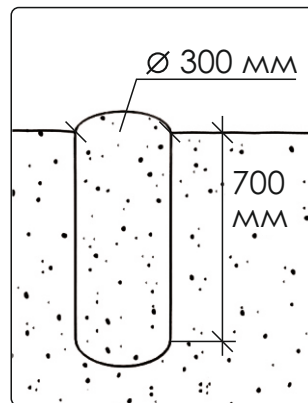

E-014

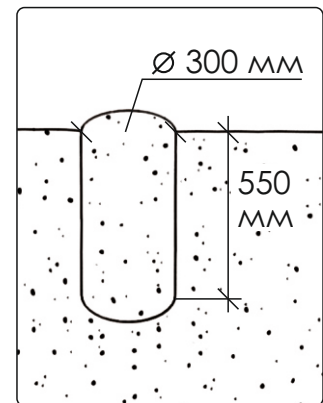

3. PREASSEMBLY OF ELEMENTS

a

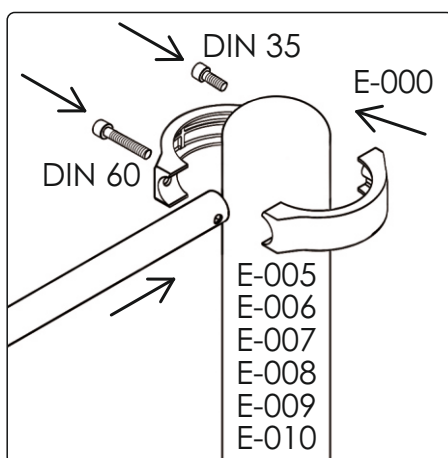

b

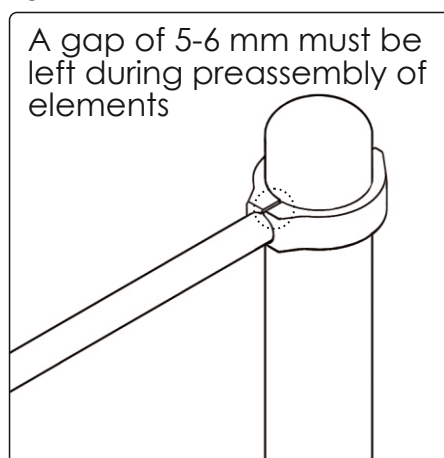

Element assembly using clamps must be carried out on a specially prepared surface to avoid damaging the paint-and-lacquer coating.

4. CHECKING VERTICALITY AND ANCHORING COLUMNS

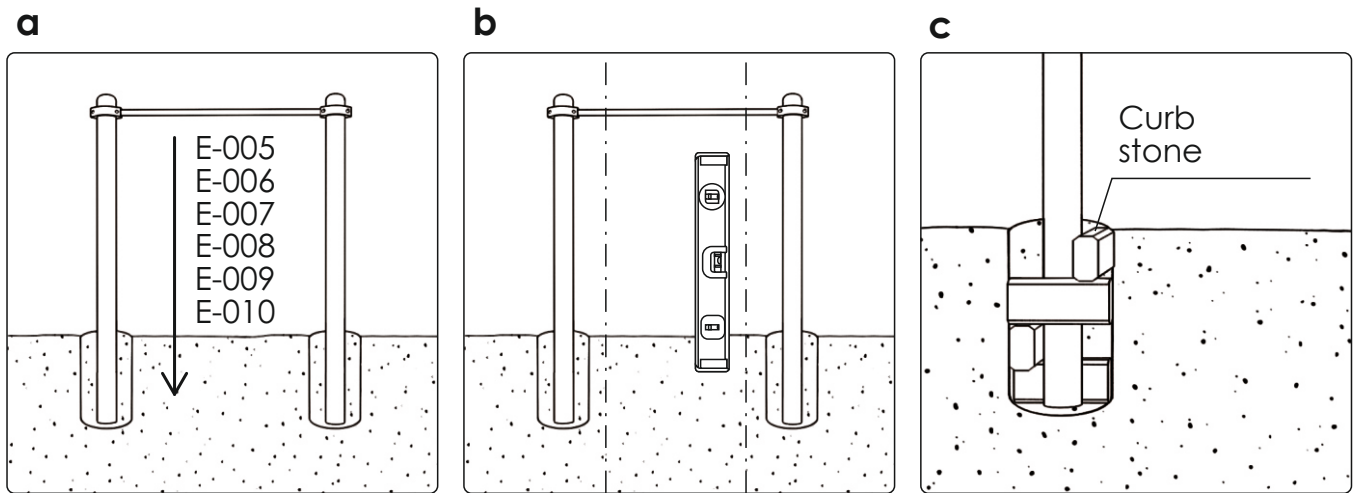

5. CHECKING HORIZONTALITY AND FASTENING ELEMENTS

MAXIMUM TORQUE OF THREADED CLAMP FASTENER DURING INSTALLING = 50-55 Nm

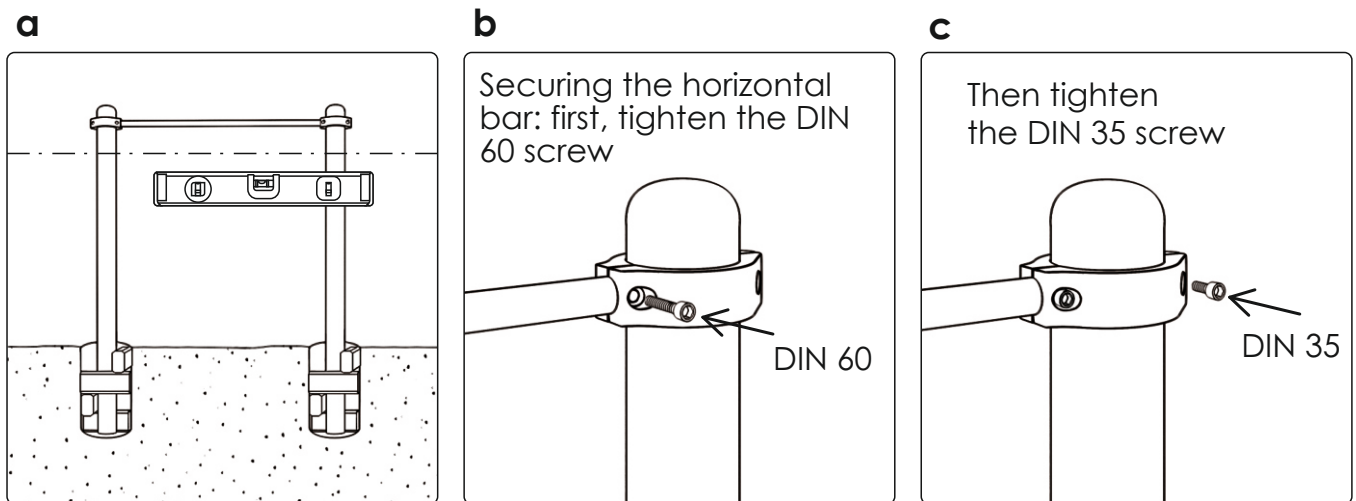

6. CONCRETE POURING

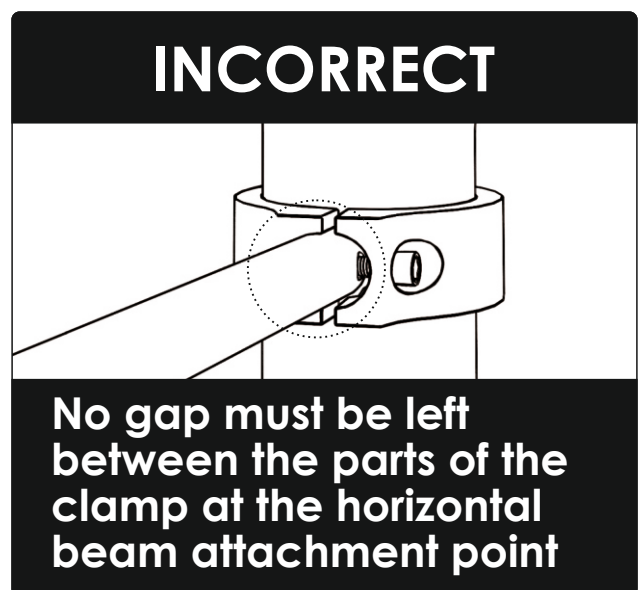
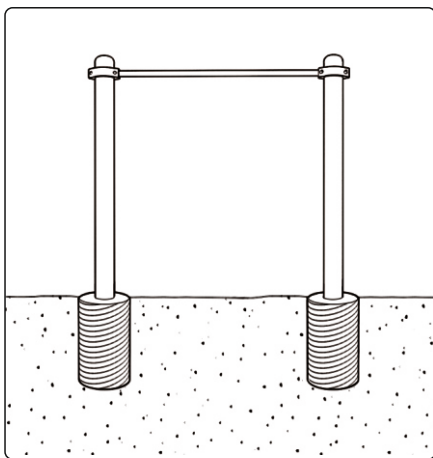



OUTDOOR ELEMENTS

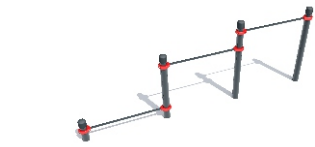

K-001

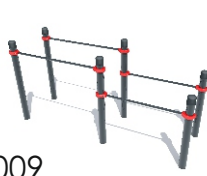

K-009



K-017

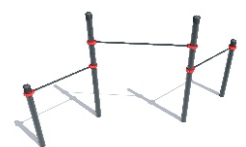

K-025

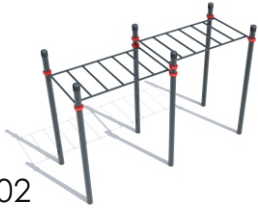

K-002

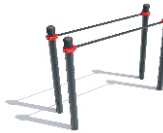

K-010



K-018



K-026

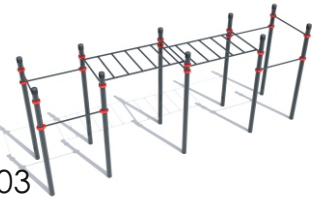

K-003

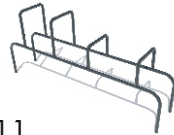

K-011



K-019

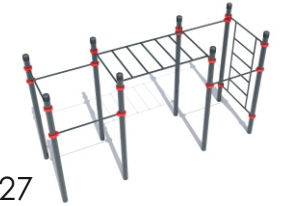

K-027

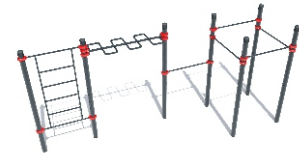

K-004

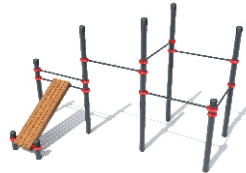

K-012



K-020



K-028

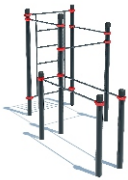

K-005

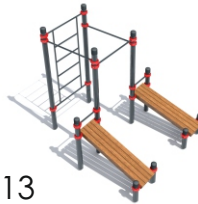

K-013



K-021

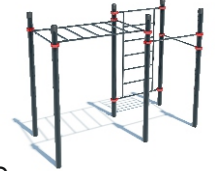

K-029



K-006



K-014

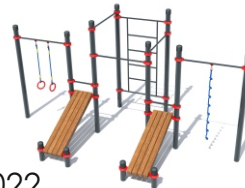

K-022



K-030



K-007

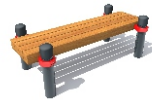

K-015



K-023

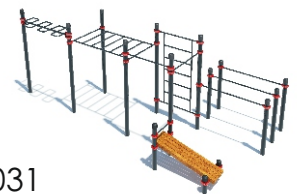

K-031



K-008



K-016

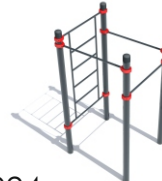

K-024

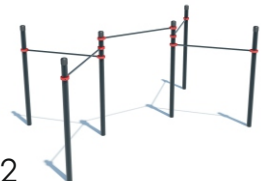

K-032

	E-001	E-002	E-003	E-005	E-006	E-007	E-008	E-009	E-010	E-011	E-012	E-013	E-014	E-016	E-017	F-007	П- Rope	П- Ring	Rope	Ring	E-000	DIN 35	DIN 60
K-001		3		1	1	2															6	6	6
K-002									6			2									8	8	8
K-003		6							10			2									20	20	20
K-004		5							7		1			1							18	18	18
K-005		3	2			3		1	3		1										14	14	14
K-006									2		1										4	4	4
K-007		1							2												2	2	2
K-008													2										
K-009		2	2		2	4															8	8	8
K-010			2			4															4	4	4
K-011										1													
K-012	1	7		2		2		2	2						4						16	16	16
K-013	6	3		4	1	1		1	3		1				8						22	22	22
K-014		2						1	2												4	4	4
K-015	2			4											4						4	4	4
K-016		3									3										6	6	6
K-017		5								4											10	10	10
K-018													3										
K-019	3	1	2	2		3			4		1				4						16	16	16
K-020							2																
K-021	3	4		3		1		1	3		1				4						18	18	18
K-022	6	3		4					8		1				8		1	1	1	2	26	26	26
K-023	3			2		2									4						6	6	6
K-024		3						1	3		1										10	10	10
K-025		2	1			2		2													6	6	6
K-026		3					2		6			1				1					14	14	14
K-027		5							8		1	1									18	18	18
K-028	6			2	6										12						12	12	12
K-029		2						1	5		1	1									12	12	12
K-030	3	6	1	2	1			2	7		1	1			4						28	28	28
K-031	3	2	3	2	1	5			7		1	1		1	4						28	28	28
K-032			5						6												10	10	10



© 2017

WWW.KENGURUPRO.EU
E-MAIL: INFO@KENGURUPRO.EU